

STRUCTURE Silicon Monolithic Integrated Circuit

PRODUCT SERIES Reversible Motor Driver for 2 motors

TYPE **BA6246**

FEATURES • Built-in 1.5 drivers
 • Output voltage can be set by a reference pin

○ ABSOLUTE MAXIMUM RATINGS (Ta=25°C)

Parameter	Symbol	Ratings	Unit
Supply voltage	VCC1, 2	20	V
Output current	IOMAX	1.0 * ¹	A
Input voltage	VIN	-0.2 ~ 6.0	V
Operating temperature	TOPR	-25 ~ +75	°C
Storage temperature	TSTG	-55 ~ +150	°C
Power dissipation	Pd	2.5 * ²	W
Junction temperature	Tjmax	150	°C

*1 However, do not allow current to exceed Pd and ASO (Pulse at 1/50 duty: 50ms).

*2 When used at Ta=25°C or higher, derated at 20mW/°C.

○ RECOMMENDED OPERATING RANGE (Ta=25°C)

Parameter	Symbol	Range	Unit
Supply voltage 1	VCC1	8 ~ 18	V
Supply voltage 2	VCC2	8 ~ 18	V
VR voltage	VR	0 ~ 18	V

The product described herein is not designed to be X ray proof.

The product described herein is a strategic product (and/or service) subject to COCOM regulations.

It should not be exported without authorization from the appropriate government.

Status of this document

The Japanese version of this document is the formal specification.

A customer may use this translation version only for a reference to help reading the formal version.

If there are any differences in translation version of this document, formal version takes priority.

○ ELECTRICAL CHARACTERISTICS (Unless otherwise specified, Ta=25°C, VCC1=VCC2=12V)

Parameter	Symbol	Limits			Unit	Conditions
		Min.	Typ.	Max.		
Supply current	ICC	-	7	15	mA	IN1, IN2, IN3=OPEN
Input threshold voltage H	VIH	3.5	-	-	V	
Input threshold voltage L	VIL	-	-	1.0	V	
Output voltage H	VOH	10	10.5	-	V	Io=0.5A, VR=OPEN
Output voltage L	VOL	-	0.9	1.5	V	Io=0.5A
Output leak current	IOL	-	-	1	mA	IN1, IN2, IN3=L VCC2 current
Output offset voltage	VOFS	-0.5	0	0.5	V	VR=6V, Io=0.5A, VOUT-VR
VR bias current	Ib	0.5	0.8	1.6	mA	VR=6V, Io=0.5A

○ DIMENSIONS AND MARKING

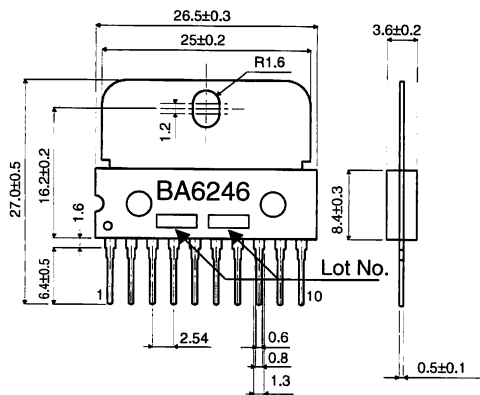

HSIP10 (Unit:mm)

○ BLOCK DIAGRAM

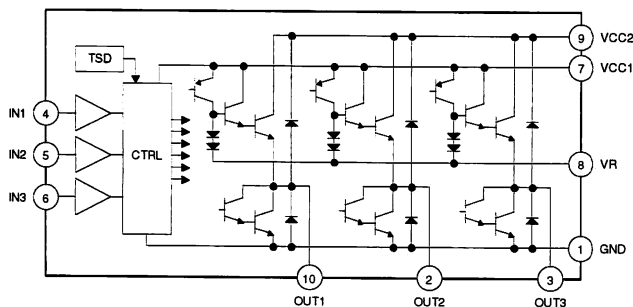

○ PIN DESCRIPTION

Pin	Name
1	GND
2	OUT2
3	OUT3
4	IN1
5	IN2
6	IN3
7	VCC1
8	VR
9	VCC2
10	OUT1

○ CAUTIONS ON USE

- 1) Absolute Maximum Ratings
For the present product, thoroughgoing quality control is carried out, but in the event that applied voltage, working temperature range, and other absolute maximum rating are exceeded, the present product may be destroyed. Because it is unable to identify the short mode, open mode, etc., if any special mode is assumed, which exceeds the absolute maximum rating, physical safety measures are requested to be taken, such as fuses, etc.
- 2) Reverse connection of power supply connector
Reverse connection of power supply connector may destroy the IC. Take necessary measures to protect the IC from reverse connection breakage such as externally inserting diodes across power supply and IC power supply terminal as well as across power supply and motor coil.
- 3) Power supply line
Because return of current regenerated by Back-EMF of a motor occurs, take necessary measures such as inserting capacitors across the power supply and GND as a path for regenerated current, and determine the capacity value after thoroughly confirming that there would be no problems in various characteristics such as capacitance drop at low temperature which may occur with electrolytic capacitors. By the way, in the event that the power supply connected does not have sufficient current absorbing capability, voltage of the power supply line rises due to regenerative current and there is a fear in that the present product including the peripheral circuits exceeds the absolute maximum rating. It is therefore requested to provide physical safety measures, such as inserting a diode for voltage clamp across power supply and GND, etc.
- 4) Electrical potential at GND
Keep the GND terminal potential to the minimum potential under any operating condition. In addition, check if there is actually any terminal, which provides voltage below GND including transient phenomena.
- 5) Thermal design
Consider the power dissipation (Pd) under actual working condition and carry out thermal design with sufficient margin provided.
- 6) Short-circuiting between terminals, and mismounting
When mounting to PCB, care must be taken to avoid mistake in its orientation and alignment. Failure to do so may result in IC breakdown. Short-circuiting due to foreign matters entered between output terminals, or between output and power supply or GND may also cause breakdown.
- 7) Operation in strong electromagnetic field
The use in the strong electromagnetic field may sometimes cause malfunction, to which care must be taken.
- 8) ASO
When IC is used, design in such a manner that the output transistor does not exceed absolute maximum ratings and ASO.
- 9) Built-in thermal shutdown circuit
The thermal shutdown circuit is first and foremost intended for interrupt IC from thermal runaway, and is not intended to protect and warrant the IC. Consequently, never attempt to continuously use the IC after this circuit is activated or to use the circuit with the activation of the circuit premised.
- 10) Capacitor across output and GND
In the event a large capacitor is connected across output and GND, when VCC and VIN are short-circuited with 0V or GND for some kind of reasons, current charged in the capacitor flows into the output and may destroy the IC. Use a capacitor smaller than 1 μ F between output and GND.
- 11) GND wiring pattern
If there are a small signal GND and a high current GND, it is recommended to separate the patterns for the high current GND and the small signal GND and provide a proper grounding to the reference point of the set not to affect the voltage at the small signal GND with the change in voltage due to resistance component of pattern wiring and high current. Also for GND wiring pattern of the component externally connected, pay special attention not to cause undesirable change to it.
- 12) Switching of rotating direction (FWD/REV)
When the rotating direction is changed over by the motor rotating condition, switch the direction after the motor is temporarily brought to the BRAKE condition or OPEN condition. It is recommended to keep the relevant conditions as follows:
 - via BRAKE: Longer than braking time*.
 - (* the time required for the output L terminal to achieve potential below GND when brake is activated.)
 - via OPEN: The time longer than 1 ms is recommended.

Notes

- No technical content pages of this document may be reproduced in any form or transmitted by any means without prior permission of ROHM CO.,LTD.
- The contents described herein are subject to change without notice. The specifications for the product described in this document are for reference only. Upon actual use, therefore, please request that specifications to be separately delivered.
- Application circuit diagrams and circuit constants contained herein are shown as examples of standard use and operation. Please pay careful attention to the peripheral conditions when designing circuits and deciding upon circuit constants in the set.
- Any data, including, but not limited to application circuit diagrams information, described herein are intended only as illustrations of such devices and not as the specifications for such devices. ROHM CO.,LTD. disclaims any warranty that any use of such devices shall be free from infringement of any third party's intellectual property rights or other proprietary rights, and further, assumes no liability of whatsoever nature in the event of any such infringement, or arising from or connected with or related to the use of such devices.
- Upon the sale of any such devices, other than for buyer's right to use such devices itself, resell or otherwise dispose of the same, no express or implied right or license to practice or commercially exploit any intellectual property rights or other proprietary rights owned or controlled by
- ROHM CO., LTD. is granted to any such buyer.
- Products listed in this document are no antiradiation design.

The products listed in this document are designed to be used with ordinary electronic equipment or devices (such as audio visual equipment, office-automation equipment, communications devices, electrical appliances and electronic toys).

Should you intend to use these products with equipment or devices which require an extremely high level of reliability and the malfunction of which would directly endanger human life (such as medical instruments, transportation equipment, aerospace machinery, nuclear-reactor controllers, fuel controllers and other safety devices), please be sure to consult with our sales representative in advance.

About Export Control Order in Japan

Products described herein are the objects of controlled goods in Annex 1 (Item 16) of Export Trade Control Order in Japan.

In case of export from Japan, please confirm if it applies to "objective" criteria or an "informed" (by MITI clause) on the basis of "catch all controls for Non-Proliferation of Weapons of Mass Destruction.